

Features

- 200Watts peak pulse power ($T_P = 8/20\mu s$)
- SOD-523FL package
- Unidirectional configurations
- Low clamping voltage
- Low leakage current
- Medium capacitance ($C_J=45pF$ typ.)
- Protection one data/power line to:
 ISO 10605 $\pm 15kV$ contact $\pm 25kV$ air
 IEC 61000-4-4 (EFT) 40A (5/50ns)
 IEC 61000-4-5 (Lightning) 8A (8/20 μs)
- AEC-Q101 Qualified

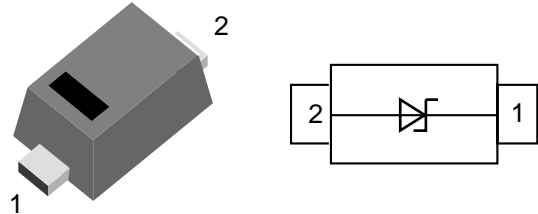

Mechanical Data

- **Case:** SOD-523FL (plastic package).
Lead free; RoHS compliant; Halogen free
- **Molding Compound Flammability Rating:**
UL 94 V-0
- **Terminals:** High temperature soldering guaranteed:
260 °C/10 sec. at terminals

Applications

- Computers and peripherals
- Communication systems
- Notebook
- Cellular handsets and accessories
- Portable electronics
- Audio and video equipment

Absolute Maximum Ratings

Ratings at 25 °C, ambient temperature unless otherwise specified

Parameter	Symbol	Value	Unit
Peak Pulse Power ($T_P=8/20\mu s$)	P_{PP}	200	W
ESD contact/air discharge (ISO 10605)	V_{ESD}	15/25	kV
Peak Pulse Current ($T_P = 8/20\mu s$)	I_{PP}	8	A
Junction Temperature	T_J	-55 to +125	°C
Storage temperature	T_{STG}	-55 to +150	°C

Electrical Characteristics

($T_A = 25$ °C unless otherwise specified)

Parameter	Symbol	Condition	Min	Typ	Max	Unit
Reverse stand-off Voltage	V_{RWM}				12	V
Reverse Breakdown Voltage	V_{BR}	$I_T=1mA$	13.3	15.0		V
Reverse Leakage Current	I_R	$V_R=12V$			1	μA
Clamping Voltage	V_C	$I_{PP}=5A, T_P=8/20\mu s$			20	V
Clamping Voltage	V_C	$I_{PP}=8A, T_P=8/20\mu s$		25		V
Junction Capacitance	C_J	$V_R=0V, f=1MHz$		45		pF



Typical Characteristics ($T_{amb} = 25\text{ }^{\circ}\text{C}$ unless otherwise specified)

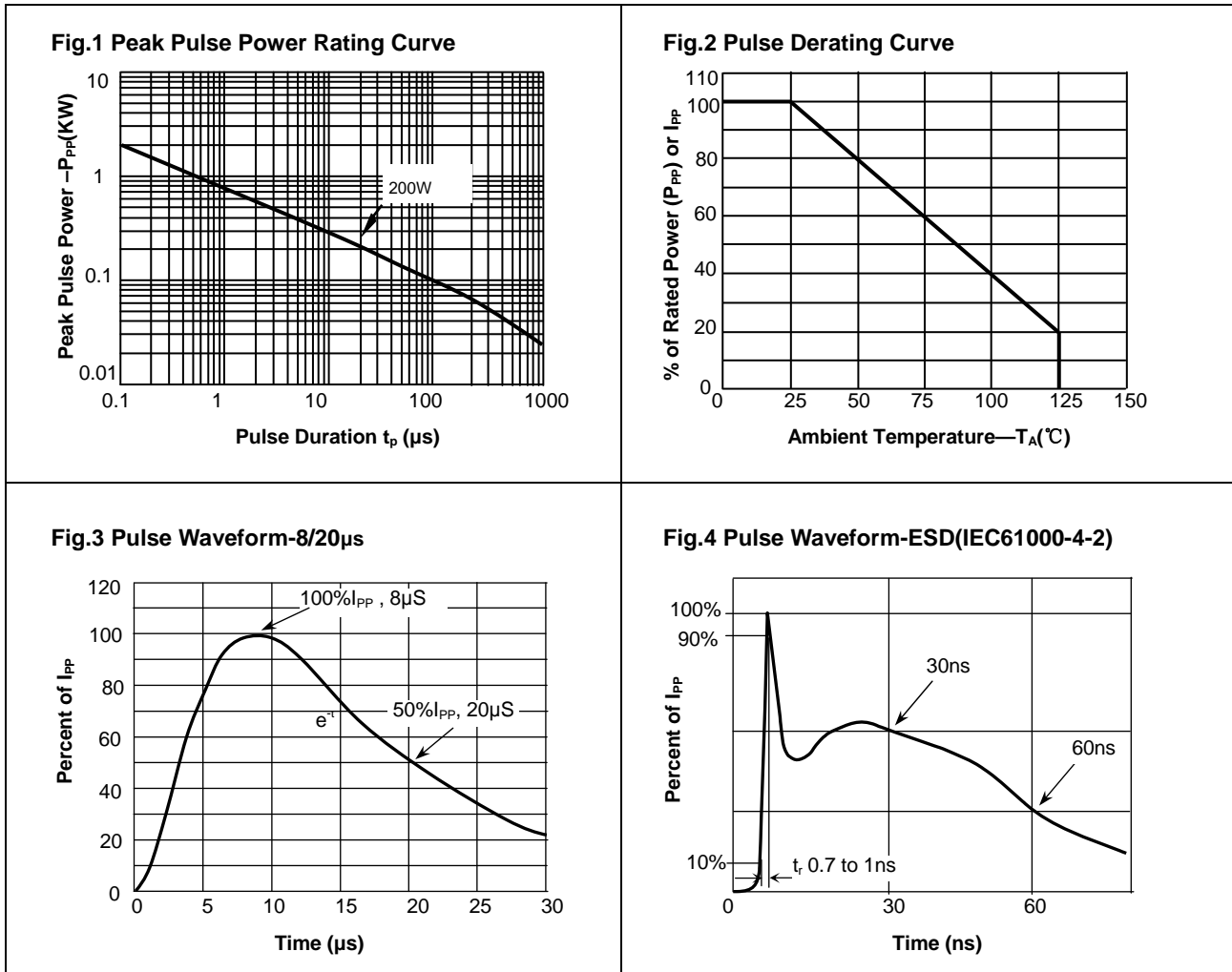

Package Dimensions

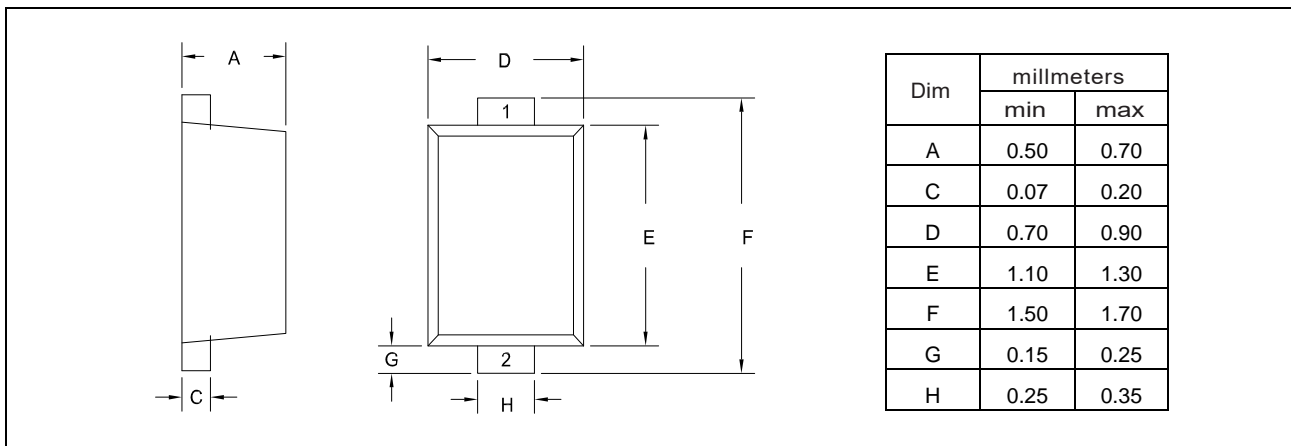

Pad Dimensions

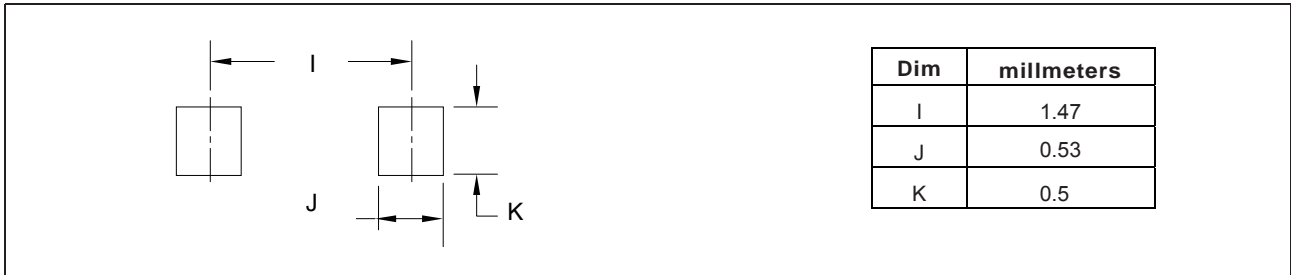

Package Dimensions

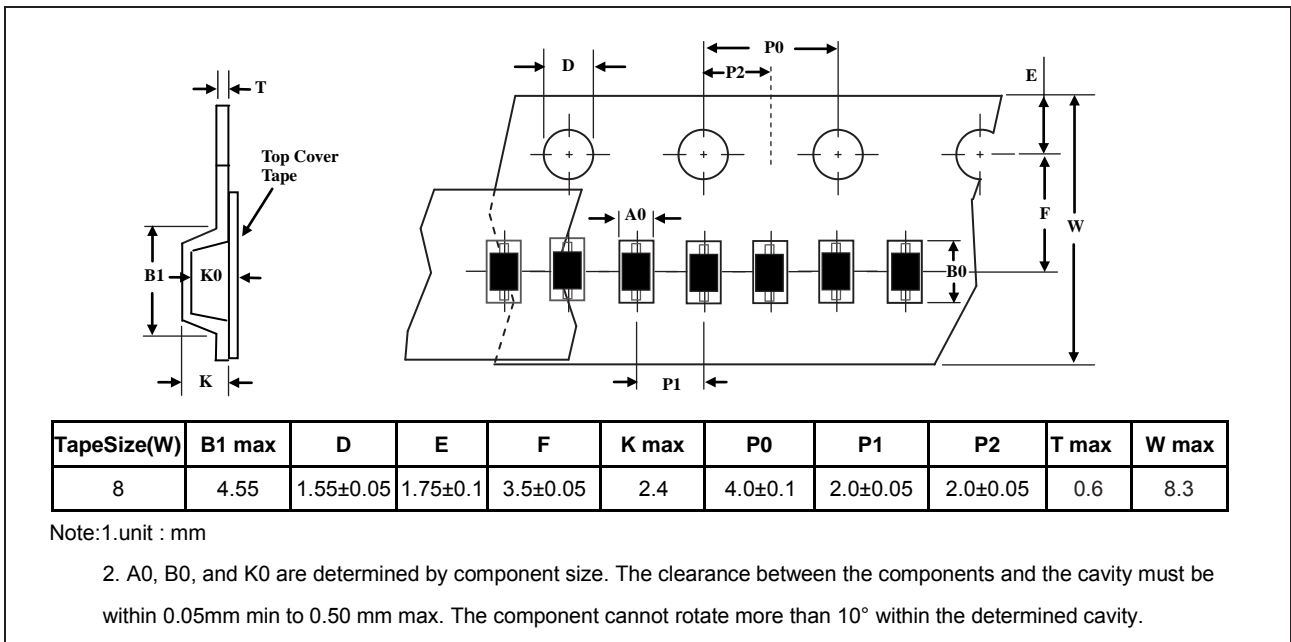

Marking



Ordering information

Order code	Package	Packaging option	Base quantity	Packaging specification
YEDSD521208AQ	SOD-523FL	Tape and reel	5000pcs / reel	EIA STD RS-481